



LAUDA

OVERALL BROCHURE
CONSTANT TEMPERATURE
EQUIPMENT
2026/2027

°FAHRENHEIT. °CELSIUS. °LAUDA.

LAUDA CIRCULATION AND PROCESS THERMOSTATS

°LAUDA

Specific application examples

- Refractometer
- Polarimeter
- Single-use bioreactors
- Extruder for food production
- Micro reactors
- Responsive control in chemical/pharmaceutical surroundings
- Climate chambers
- Space simulation
- Electric mobility; battery testing
- Test rigs
- Stress test
- Crystallization regulation
- Freeze-drying
- Micro structures
- Coating plants



LAUDA LOOP

The compact, lightweight circulation thermostat for external applications from 4 to 80 °C

4°C  80°C

Extremely versatile, flexibly usable thermo-electric circulation thermostat

The LAUDA LOOP circulation thermostat is sure to impress with its constant temperature range between 4 and 80 °C. Its compact construction and low weight, as well as wide voltage input range of 100 to 240 volts, make it possible to put it to use flexibly and spontaneously anywhere in the world – the ›Plug & Play‹ setup with quick-fit couplings makes it especially easy to use. The intuitive three-button softkey operation and simple menu navigation in five available languages via the well-lit, high-contrast OLED display make using the device a breeze.



Simple three-button controls with OLED display



Standard-issue RS-232 interface for system integration into processes

PUMP CHARACTERISTIC Heat transfer liquid: Water

Pressure bar

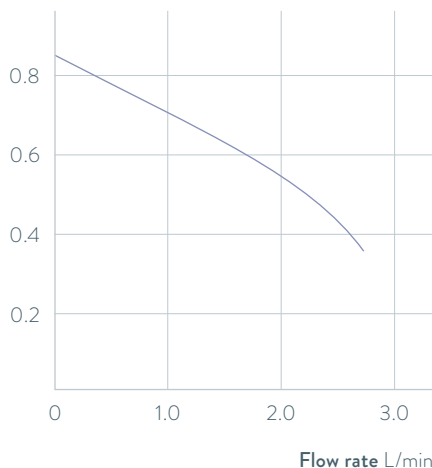

Important functions

- Pump connections with quick-fit couplings for easy consumer changes
- Can be operated with non-flammable liquids (water, water/glycol)
- Cooling technology free of coolant ensures silent, low-vibration operation

Included accessories

Hose nozzles for pump connections

Further accessories

Tubing

All technical data and power supply variants can be found in the ›Technical data‹ section.

More at www.lauda.de/de/1748



LAUDA LOOP

The L 100 and L 250 air-cooled device types achieve a cooling capacity of 120 and 250 watt. The devices are primarily for use at constant temperatures with low power requirements. Both device types are especially energy-efficient and silent in partial-load operation.



LAUDA PRO

Compact circulation thermostats for professional temperature control from -90 to 250 °C



Flexible operation, outstanding performance characteristics

LAUDA PRO is the cutting-edge product line with an outstanding overall concept: The circulation thermostats with small, active volumes of liquid enable rapid temperature changes in external applications. The innovative Base or Command Touch operating units can be detached and used as a remote control. The cooling thermostats come equipped with hybrid cooling as standard, which allows for additional cooling of the refrigerating machine with water.



Many basic functions with the economic Base variant

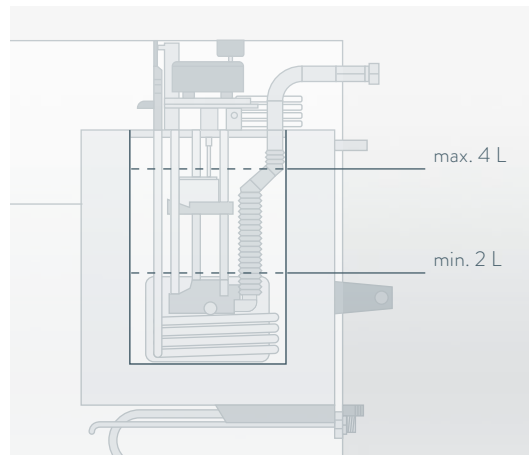

The small filling volume and powerful vario flex pump offer fast temperature changes with low operating costs and material consumption

PUMP CHARACTERISTICS Heat transfer liquid: Water

Pressure bar

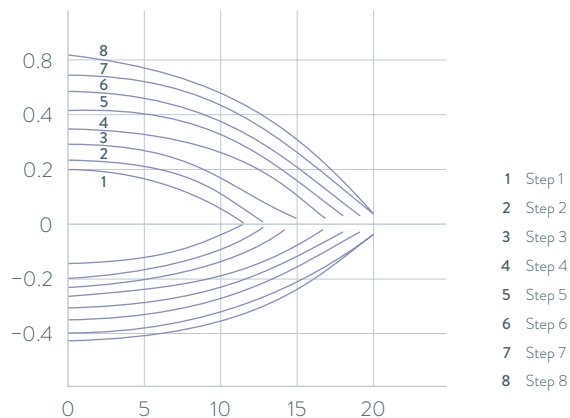

Suction

Flow rate L/min

Important functions

- Tower design for small footprint
- LAUDA Vario Flex Pump with 8 available output levels, pump connections at rear
- SmartCool system for digital, energy-saving cooling control including automatic compressor control

Included accessories

Tubing nipples for pumps and cooling water connection

Further accessories

Tubing, interface modules

All technical data and power supply variants can be found in the ›Technical data‹ section.

More at www.lauda.de/de/1750



LAUDA PRO

The PRO heating circulation thermostats are designed for external applications up to 250 °C. The compact construction permits space-saving installation of the thermostats. An integrated cooling coil, fitted as standard, provides cooling. The PRO cooling circulation thermostats are ideal for external applications where rapid temperature changes are required. The cooling output of 0.6 and 0.8 kW or 1.5 kW, combined with a very low filling volume permit these rapid temperature changes.



LAUDA Integral T

Process thermostats for professional external temperature control in the temperature range of -32 to $150\text{ }^{\circ}\text{C}$



LAUDA Integral T process thermostats are optimally suited to the effective monitoring of external temperature control processes in temperatures ranging from -32 to $150\text{ }^{\circ}\text{C}$. Integral T process thermostats enable fast temperature changes thanks to tailored heating outputs and cooling capacities with small internal volumes.

The open hydraulic system means that the device vents quickly without any impairment of function, and is thus ideal for temperature controlling processes with frequent changes of consumer or user.

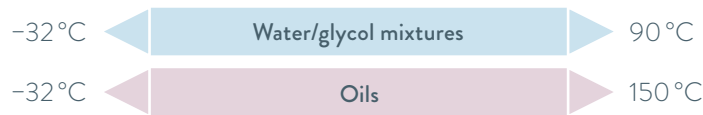

Three different housing sizes, depending on the output power



Ethernet, USB, malfunction contact and Pt100 as standard, two module slots for additional interfaces

INTEGRAL T HYDRAULIC DIAGRAM

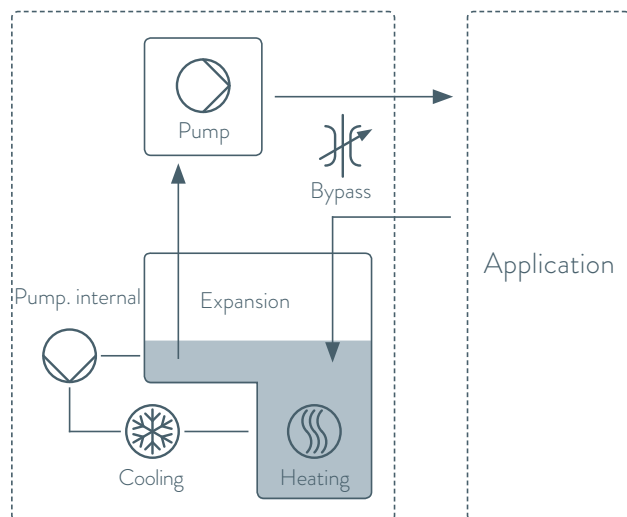

Important functions

- Compact, open bath system with large expansion volume
- Programmer with 150 temperature/time segments
- Self-adaption of the controller for optimized temperature control
- Adjustable bypass for pressure limitation
- Filling from above, drainage from the side
- Electronic level monitoring
- Operation in internal LAN possible on web server via PC or tablet/smartphone
- Remote monitoring and maintenance via LAUDA.LIVE

Included accessories

Nipples for pump connections

Further accessories

Tubing, 4-port manifold

All technical data and power supply variants can be found in the [Technical data](#) section.

More at www.lauda.de/de/1752

LAUDA.LIVE
ready



LAUDA Integral T

The bypass in the Integral T reduces the linear pump characteristics when it opens. Pressure-sensitive applications can therefore be protected by reducing the discharge pressure. The digital pressure indication in the Integral T display facilitates manual adjustment of the discharge pressure by means of a bypass. The robust and powerful immersion pressure pump ensures reliable, leak-free and safe operation. The independent internal circulation of the heat transfer liquid ensures maximum heating and cooling capacity.



LAUDA Integral XT

High-performance process thermostats from 1.5 to 35 kW for temperature control from -90 to 320 °C



LAUDA Integral XT process thermostats operate according to the flow principle with a cold oil overlay which enables the utilization of temperature control media over a significantly larger temperature range—optimal for dynamic temperature control tasks.

The electronically controlled, magnetically coupled pump can set the flow rate optimally both for the requirements of pressure-sensitive consumers and for applications with high hydraulic resistance.



TFT display with different screens or temperature profiles



Bypass included as standard. For increased internal flow rates in applications requiring pressure limitations

INTEGRAL XT HYDRAULIC DIAGRAM

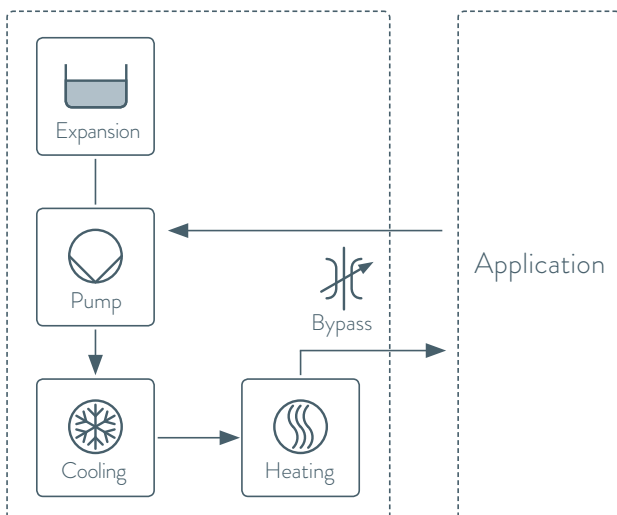

Important functions

- High-performance LAUDA Vario Pump (pressure pump) with 8 selectable output levels or flow pressure control
- Programmer with 150 temperature/time segments, can be divided into five programs
- Two additional interface modules available for retrofit
- Operation in internal LAN possible on web server via PC or tablet/smartphone
- Remote monitoring and maintenance via LAUDA.LIVE

Standard equipment

Ethernet and USB interfaces, Pt100 and malfunction contact

Additional accessories

Hoses, adapters, through-flow control systems, filling and emptying systems

All technical data and power supply variants can be found in the ›Technical data‹ section.

More at www.lauda.de/de/1754

LAUDA.LIVE
ready



LAUDA Integral XT

The Integral XT uses an eight-stage, robust and magnetically coupled Vario pump with selectable characteristics to ensure a reliable supply to the consumer, even with high flow resistance. The menu-driven selection of the pump level enables optimum thermal connection of the application with the required pressure and volume flow rate.



Circulation and process thermostats

Circulation chillers

Immersion/bath circulation thermostats

Water baths

Deep-freezers

Stills

Digital products

Accessories, Service

LAUDA Integral P

High-performance process thermostats from 20 to 35 kW for temperature control from -40 to 140 °C



The **LAUDA Integral P** process thermostats function according to the flow principle, with a pressure overlay of up to 4 bar. This allows non-flammable water/glycol mixtures to be used in a temperature range of -40 to 140 °C.

Thanks to the electronically controlled, magnetically coupled pump, optimized flow rates can be set for different applications.

-40 °C  **Water/glycol mixtures**  140 °C

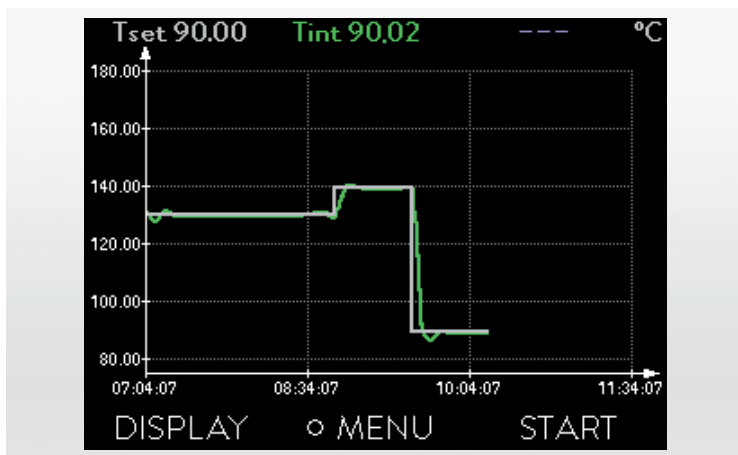

TFT display with different screens or temperature profiles



Bypass included as standard. For increased internal flow rates in applications requiring pressure limitations

INTEGRAL P HYDRAULIC DIAGRAM

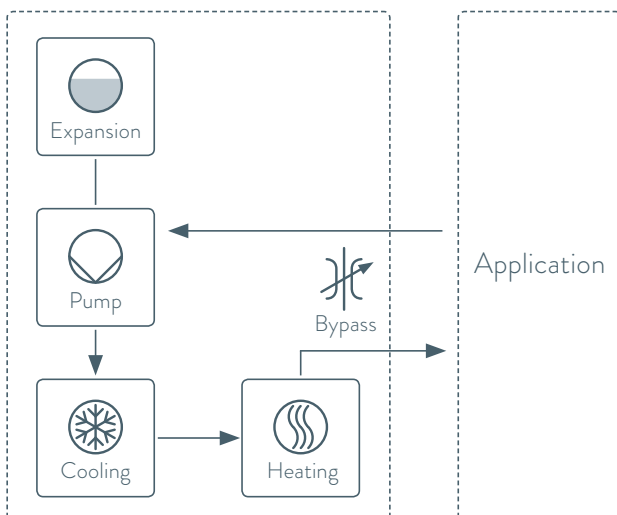

Important functions

- High-performance LAUDA Vario pump (pressure pump) with 8 selectable output levels or flow pressure control
- Programmer with 150 temperature/time segments, can be divided into five programs
- Two additional interface modules available for retrofit
- The LAUDA Command app enables wireless device operation on external devices such as PCs, tablets, and smartphones within the network
- Venturi element for vacuum filling
- Remote monitoring and maintenance via LAUDA.LIVE

Standard equipment

Ethernet and USB interfaces, Pt100 and malfunction contact

Additional accessories

Hoses, adapters, through-flow control systems

All technical data and power supply variants can be found in the [Technical data](#) section.

More at www.lauda.de/de/1755



LAUDA.LIVE
ready

LAUDA Integral P

The LAUDA Integral P process thermostats can generate a static pressure of up to 4 bar with compressed air. This makes it possible to use non-flammable water-glycol mixtures, which have a high vapor pressure in open-atmosphere temperature control systems, from -40 to 140 °C. This can significantly reduce operating costs compared to the use of combustible heat transfer media. Filling can be carried out either via a vacuum generated by compressed air or via a drum pump provided by the customer.



LAUDA Integral XT and P variants

Additional products for functional expansion



LAUDA FLOW CONTROL

FC 80 C

NEW

- Flow control system with Coriolis measuring method
- Ideal for dielectric cooling media with immersion cooling
- Suitable for all temperature control media
- Available as a floor-standing or surface-mounted solution

FC 80 MID

- Flow control system with magnetic inductive measurement principle
- Ideal for water/glycol and conductive temperature control media
- Available as a floor-standing or surface-mounted solution

More at www.lauda.de/de/1825

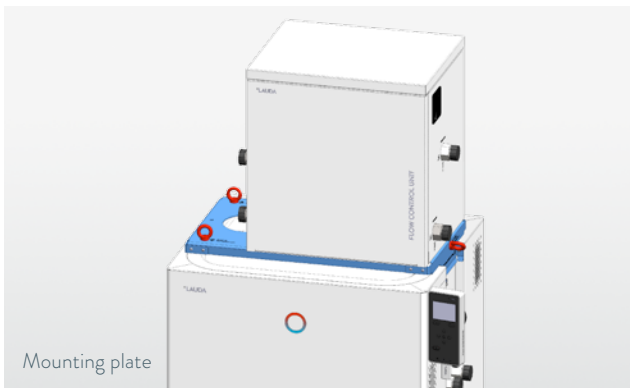

Mounting plate

- For flow control on Integral (shown in blue)
- Depending on the housing size of the Integral

More at www.lauda.de/de/1827



LAUDA FILLING AND DRAINING UNIT

FD 50

- For non-flammable liquids
- Buffer volume up to 50 L
- Safe temperature before emptying
- Leak test via compressed air
- Rapid venting

More at www.lauda.de/de/1826

FD 50 F

- For flammable liquids

LAUDA Integral XT
Process thermostat

LAUDA FC 80 MID/FC 80 C
Flow control unit

LAUDA FD 50/FD 50 F
Filling and draining unit

Climate chamber

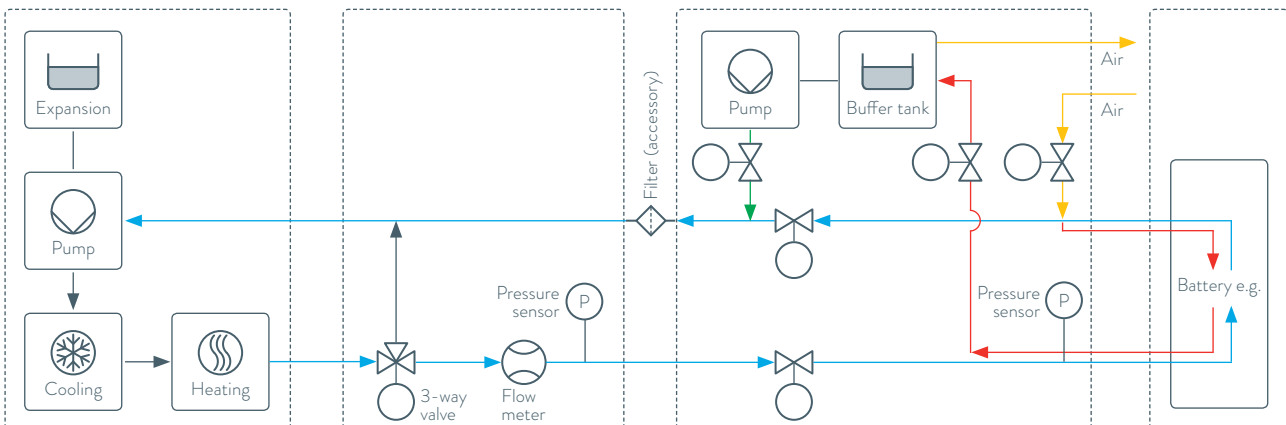

NEW



Functional enhancements for LAUDA Integral XT and P variants

The LAUDA filling and flow control system based on FD 50 and FC 80 MID is the perfect combination for standardized test and inspection procedures for water/glycol mixtures as temperature control media.

The LAUDA filling and emptying system FD 50 F can also handle flammable media and, together with the FC 80 C, is optimized for dielectric temperature control media.



Circulation and process thermostats

Circulation chillers

Immersion/bath circulation thermostats

Water baths

Deep-freezers

Stills

Digital products

Accessories, Service

LAUDA Variocool

Process thermostats from -25 to $80\text{ }^{\circ}\text{C}$
with cooling capacities up to 10 kW and powerful pumps

$-20\text{ }^{\circ}\text{C}$  $80\text{ }^{\circ}\text{C}$

Powerful and flexible in use

A comprehensive performance spectrum enables the LAUDA Variocool to deal with sophisticated process temperature control in the moderate temperature range. Equipment incorporating various pumps and individual expansion with interface modules, including the option of external temperature control, allow optimized adaptation to changing requirements in the process environment.



Malfunction contact included as standard. A Pt100 module for external temperature control and interfaces for analog and digital communication can also be added.



Analog pressure indication for operational control, can be adjusted via the bypass on the back of the device

PUMP CHARACTERISTIC Heat transfer liquid: Water

Pressure bar

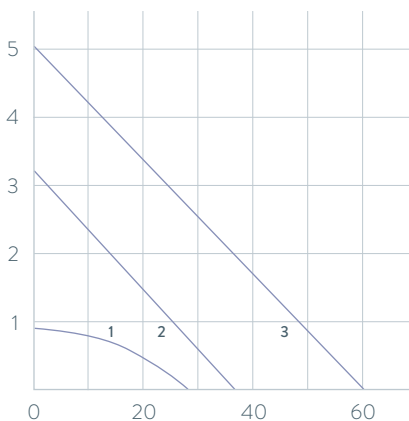

Flow rate L/min

- 1 0.9 bar, 28 L/min
- 2 3.2 bar, 37 L/min
- 3 5.0 bar, 60 L/min

Important functions

- Adjustable bypass for pressure limitation
- Filling opening at the top, drain tap at the rear
- Integrated programmer with 150 segments, can be divided into 5 programs
- Electronic level indicator and low-level alarm
- SmartCool system for digital, energy-saving cooling control, including automatic compressor control

Included accessories

Nipples, screw caps

Further accessories

Hoses, interface modules

All technical data and power supply variants can be found in the [Technical data](#) section.

More at www.lauda.de/de/1756



LAUDA Variocool

All models are available in air and water-cooled versions (W) and fitted with moveable as well as fixable castors. High-performance process thermostats in a tower design starting from the VC 5000 model are available with sound insulation.



LAUDA Ultratemp

Process thermostats with heating and cooling capacities of up to 50 kW for reactor volumes of up to 5,000 liters

-5°C  60°C

Powerful temperature control at low operating costs: LAUDA Ultratemp

The new Ultratemp process thermostats round off the LAUDA portfolio in the upper performance range of biotech and industrial applications.

The devices are specially designed for these applications. As a result, they provide e.g. the requisite high heating and cooling capacities for long process times with constant temperatures of 37°C and can subsequently cool down the reactor content very quickly.

The new Ultratemp line means that LAUDA can offer solutions for reactors and mixers with a volume of up to 5,000 liters.



LAUDA temperature solutions for applications with reactor volumes of up to 5,000 liters – perfect for biotech and industrial applications



Easy operation, even with gloves on



The high-quality stainless steel housing is protected against splash water and allows easy cleaning of the surfaces

Important functions

- Intuitive operation directly on the device via LCD or via an integrated web server on the PC
- High temperature stability of ± 0.5 K
- Simple handling and low operating costs, thanks to non-combustible heat transfer fluid of water or water-glycol
- Ready for digital applications from LAUDA.LIVE
- Extensive connectivity
- Worldwide use, thanks to dual-frequency power supply 400 V; 3/PE; 50 Hz & 460 V; 3/PE; 60 Hz

Standard equipment

Splash-protected stainless steel housing, LCD with menu navigation in clear text, protection class IP54

Further accessories

Pressure-reducing valve, water solenoid valve kit, installation kit

All technical data and power supply variants can be found in the ›Technical data‹ section.

More at www.lauda.de/de/1800

LAUDA.LIVE
ready



LAUDA Ultratemp

The Ultratemp portfolio includes three models of constant temperature equipment with high heating and cooling capacities from 25 to 50 kW, especially for bioreactor applications with reactor volumes from 2,000 to 5,000 liters within a moderate temperature range.



LAUDA Semistat

Thermo-electric process thermostats
for the semiconductor industry from -20 to 90°C



Fast and precise temperature control for demanding processes

The thermoelectric Semistat temperature control system offers reproducible temperature control for plasma etching applications. This system dynamically controls the temperature of the electrostatic wafer chuck (ESC) and can be used in all types of etching processes. The LAUDA Semistat thermoelectric temperature control systems are based on established principles of heat transfer used for Peltier elements. These elements allow quick and precise temperature control required for complex processes involved in the manufacture of components progressively getting smaller and smaller in size.



The Power Supply Controller (PSC) meets industry-specific SEMI S2 and F47 standards

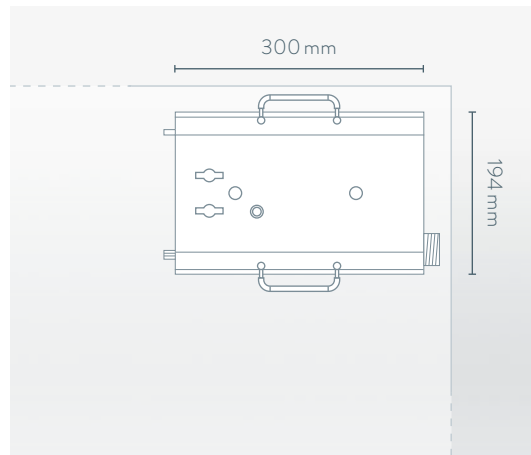

Small footprint

COOLING POWER dependent on process temperature and flow rate of cooling water

Effective cooling power kW

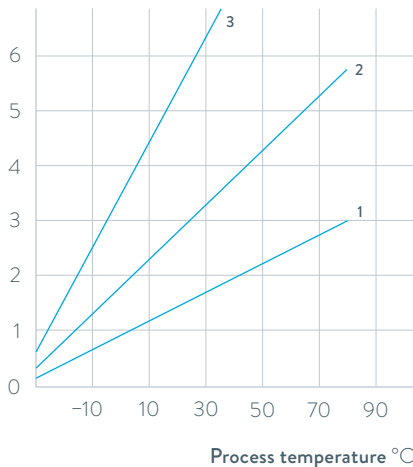

- 3 S 4400
- 2 S 2400
- 1 S 1200

Important functions

- Compressor and refrigerant-free system with low energy consumption
- Smallest footprint in the industry, ideally suited for underfloor installation
- Extremely low volume of heat transfer fluid

Available accessories

Communications modules with remote control function (RS-485 protocol)

All technical data and power supply variants can be found in the ›Technical data‹ section.

More at www.lauda.de/de/1760



LAUDA Semistat

Semistat temperature control systems can reduce energy consumption by up to 90% compared to compressor-based systems.

Minimal space requirements with the option of underfloor installation at the point of use minimizes cleanroom use.



LAUDA Circulation and process thermostats

Device type overview

LAUDA LOOP / Page 16

LAUDA PRO / Page 18

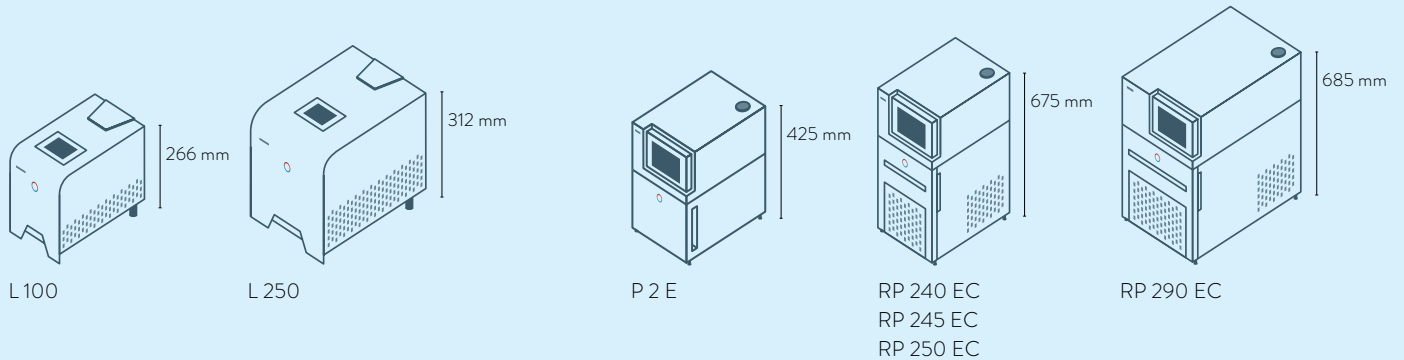

LAUDA Integral T / Page 20

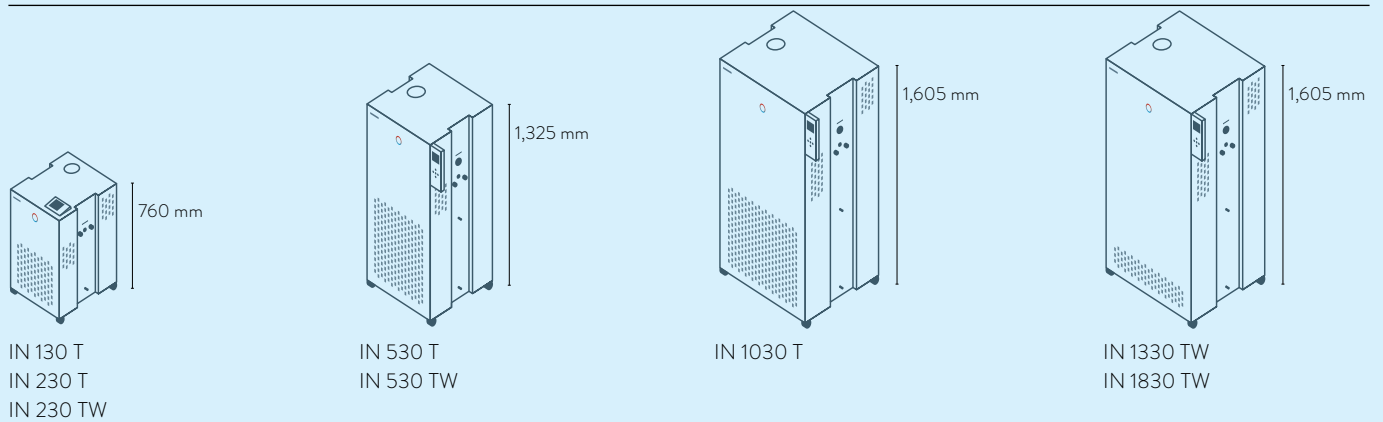

LAUDA Integral XT / Page 22

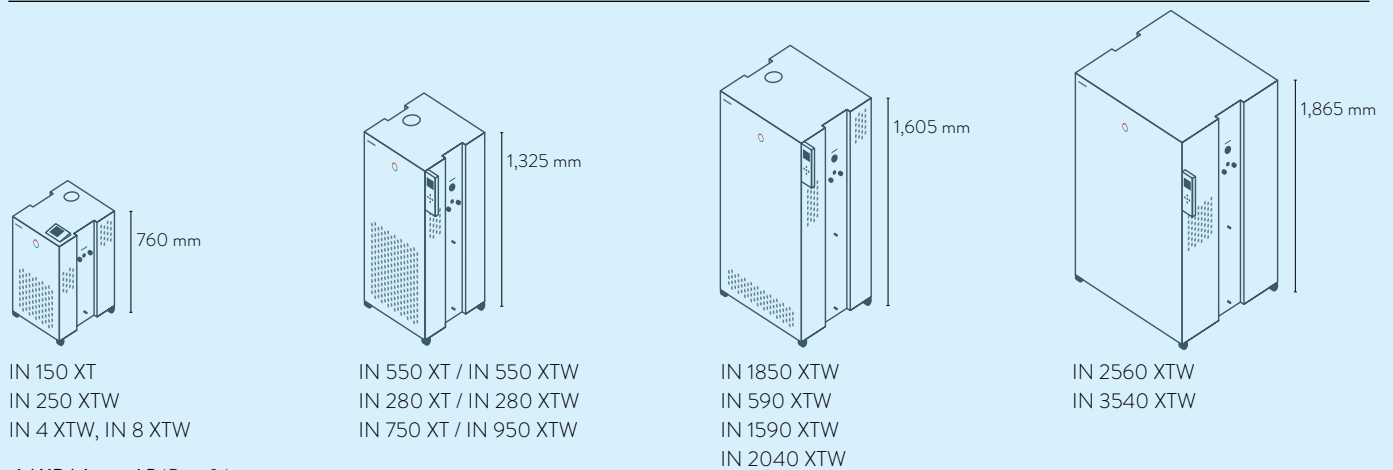

LAUDA Integral P / Page 24

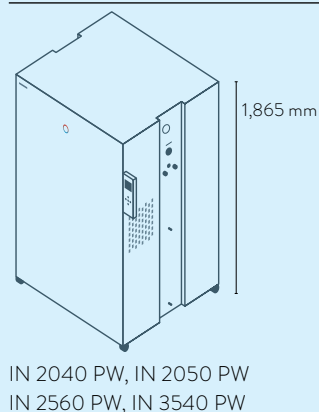

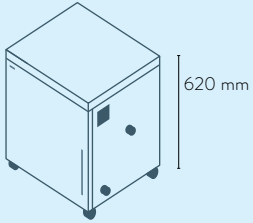

FC 80 MID

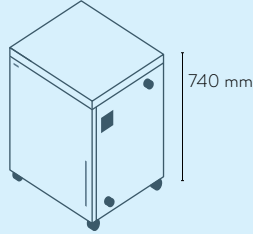

FC 80 C

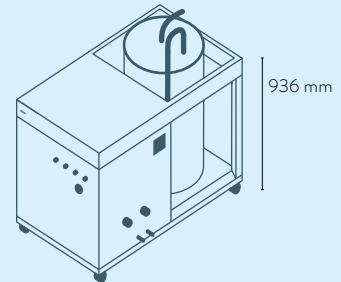

FD 50 / FD 50 F

LAUDA Variocool / Page 28

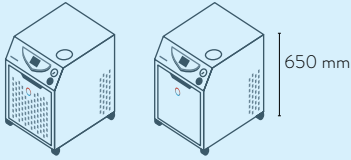

VC 1200
VC 2000

VC 1200 W
VC 2000 W

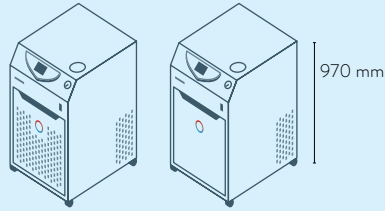

VC 5000

VC 5000 W

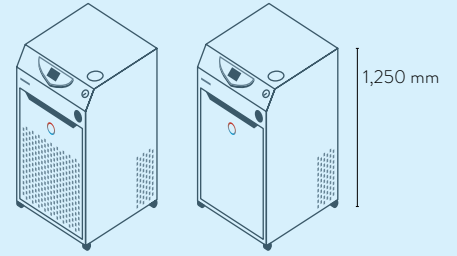

VC 10000

VC 10000 W

LAUDA Ultratemp / Page 30

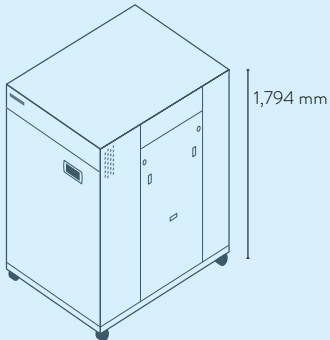

UT 2505 W
UT 3505 W

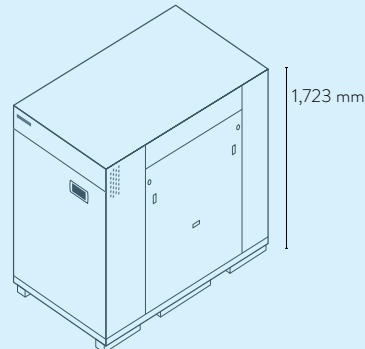

UT 5005 W

LAUDA Semistat / Page 32

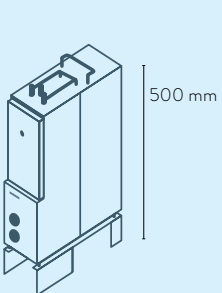

S 1200

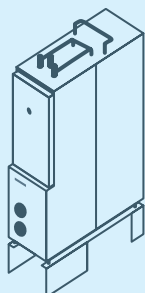

S 2400

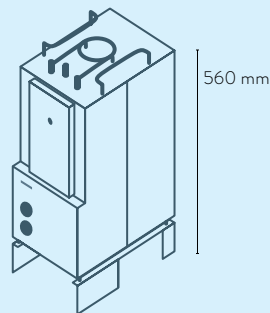

S 4400

LAUDA Circulation and process thermostats

Interfaces

	Pt 100 (1)	Pt 100 (2)	USB	Ethernet	RS-232/485	Analog	Namur contact	D-Sub contact	PROFIBUS	EtherCAT M8	EtherCAT RJ45	Malfunction contact	Number of module slots, large	Number of module slots, small	RS-232/485 module Advanced	Contact module NAMUR Advanced	Contact module D-Sub Advanced	Profibus module Advanced	Ethernet module Advanced	Profinet module Advanced	CAN module Advanced	OPC UA module Advanced	Modbus TCP module Advanced	EtherCAT module Advanced ***	EtherNet/IP module Advanced ***
LAUDA LOOP / Page 16	-	-	-	-	S	-	-	-	-	-	-	-	-	-	-	-	-	-	-	-	-	-	-	-	-
LAUDA PRO / Page 18	S	-	S	S	Z	Z	Z	Z	Z	Z	Z	-	1	-	Z	Z	Z	Z	-	Z	Z	-	-	-	-
LAUDA Integral T / Page 20	S	Z	S	S	Z	Z	Z	Z	Z	Z	Z	S	2	-	Z	Z	Z	Z	S	Z	Z	Z	Z	Z	Z
LAUDA Integral XT / Page 22	S	Z	S	S	Z	Z	Z	Z	Z	Z	Z	S	2	-	Z	Z	Z	Z	S	Z	Z	Z	Z	Z	Z
LAUDA Integral P / Page 24	S	Z	S	S	Z	Z	Z	Z	Z	Z	Z	S	2	-	Z	Z	Z	Z	S	Z	Z	Z	Z	Z	Z
LAUDA Variocool / Page 28	Z	-	S	Z	Z	Z	Z	Z	Z	Z	Z	S	1	1	Z	Z	Z	Z	Z	Z	Z	Z	Z	Z	Z
LAUDA Ultratemp / Page 30	S	-	-	S*	-	S**	-	-	-	-	-	S	-	-	-	-	-	-	-	-	-	-	-	-	-

S = Series standard

Z = Available as an accessory

S* = Ethernet with Modbus TCP/IP protocol S* = 4 - 20 mA signal

S** = Direct connection to the device. Integration of interface modules not possible.

*** from 2027

LAUDA interfaces



LRZ 912
Analog module



LRZ 913
RS-232/485
interface

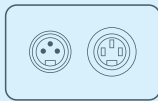

LRZ 914
Contact module, 1 input,
1 output (NAMUR)



LRZ 915
Contact module,
3 inputs, 3 outputs



LRZ 917
Profibus module

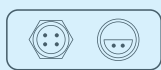

LRZ 918
Pt100/LiBus-Modul,
small cover



LRZ 921
Ethernet module

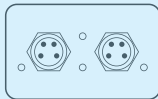

LRZ 922
EtherCAT module
with M8 connection

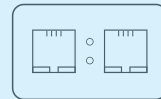

LRZ 923
EtherCAT module
with RJ45 connection



LRZ 925
External Pt100/LiBus-
module, large cover

LAUDA interfaces Advanced*



LRZ 926
RS-232/485 module
Advanced, D-Sub 9-pin



LRZ 927
Contact module NAMUR
Advanced, 1 input, 1 output



LRZ 928
Contact module D-Sub
Advanced, 3 inputs, 3 outputs



LRZ 929
Profibus module
Advanced, D-Sub 9-pin

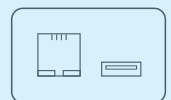

LRZ 930
Ethernet module
Advanced, RJ45

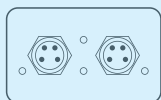

LRZ 931
EtherCAT module
Advanced, with M8 connection

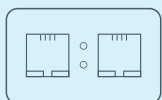

LRZ 932
Profinet module
Advanced, RJ45



LRZ 933
CAN module Advanced,
D-Sub 9-pin

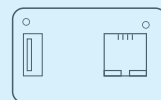

LRZ 934: OPC UA module Advanced
LRZ 935: Modbus TCP module Advanced
LRZ 936: EtherNet/IP module Advanced

* Interfaces of the Advanced generation replace modules in the process thermostats of the same name as per the above selection table

LAUDA Circulation and process thermostats

Function overview

Operating element	LOOP	PROE	PRO EC	Integral T	Integral XT	Integral P	Variocool	Ultratemp
Display	OLED	OLED	TFT	TFT	TFT	TFT	TFT	LCD
Mode of operation	3-button softkey	Cursor softkey	Multi-touch	Cursor softkey	Cursor softkey	Cursor softkey	Cursor softkey	6 buttons
Removable control	-	✓	✓	Z	Z	Z	Z	-
User management	-	-	✓	Operator / Viewer	Operator / Viewer	Operator / Viewer	-	-
Data logging, export to USB stick	-	-	✓	✓	✓	✓	-	✓
1-point calibration	✓	✓	✓	✓	✓	✓	✓	-
2-point calibration	✓	✓	✓	✓	✓	✓	-	-
Self-adaptation controller	-	-	✓	✓	✓	✓	-	-
Safety mode	-	✓	✓	✓	✓	✓	-	-
Programmer, programs/segments	-	1 / 20	100 / 5,000	5 / 146	5 / 146	5 / 146	5 / 146	-
Programmer, tolerance range function	-	✓	✓	✓	✓	✓	✓	-
Ramp function	-	-	✓	✓	✓	✓	-	-
Timer function	-	-	✓	✓	✓	✓	-	-
Countdown function	-	-	✓	-	-	-	-	-
Graphic temperature profile display	-	-	✓	✓	✓	✓	✓	-
Pump pressure display (digital)	-	-	-	✓	✓	✓	-	✓
Adjustable bypass	-	-	-	✓	✓	✓	✓	✓
Level indicator (digital)	-	✓	✓	✓	✓	✓	✓	-
Standby timer	✓	✓	✓	✓	✓	✓	✓	✓
Flow control instrument	-	-	-	-	-	-	Z	-
Flow pressure control	-	-	-	-	✓	✓	-	-
Flow measurement + control	-	-	-	-	Z	Z	-	-
Overflow	-	✓	✓	✓	✓	✓	-	-
Low-level alarm	✓	✓	✓	✓	✓	✓	✓	✓
Drain tap	-	✓	✓	✓	✓	✓	✓	✓

Z = Available as an accessory

LAUDA Circulation and process thermostats

Technical data according to DIN 12876 standard

Device type	Working temperature range °C	Temperature stability ±K	Cooling of the refrigerating machine	Heater power max. kW	Cooling output kW													
					200 °C	100 °C	20 °C	10 °C	0 °C	-10 °C	-20 °C	-30 °C	-40 °C	-50 °C	-60 °C	-70 °C	-80 °C	-90 °C

LAUDA LOOP / Page 16

L 100	4 ... 80	0.10	Air	0.2	-	-	0.12	0.06	-	-	-	-	-	-	-	-	-	-
L 250	4 ... 80	0.10	Air	0.4	-	-	0.25	0.13	-	-	-	-	-	-	-	-	-	-

LAUDA PRO with natural refrigerant / Page 18

P 2 E	80 ... 250	0.05	Water	2.5	-	-	-	-	-	-	-	-	-	-	-	-	-	-
P 2 EC	80 ... 250	0.05	Water	2.5	-	-	-	-	-	-	-	-	-	-	-	-	-	-
RP 240 E	-40 ... 200	0.05	Hybrid	2.5	-	-	0.60 ³	0.60 ³	0.60 ³	0.41 ³	0.24 ²	0.12 ²	0.02 ¹	-	-	-	-	-
RP 240 EC	-40 ... 200	0.05	Hybrid	2.5	-	-	0.60 ³	0.60 ³	0.60 ³	0.41 ³	0.24 ²	0.12 ²	0.02 ¹	-	-	-	-	-
RP 245 E	-45 ... 200	0.05	Hybrid	2.5	-	-	0.80 ³	0.80 ³	0.80 ³	0.53 ³	0.34 ²	0.15 ²	0.04 ²	-	-	-	-	-
RP 245 EC	-45 ... 200	0.05	Hybrid	2.5	-	-	0.80 ³	0.80 ³	0.80 ³	0.53 ³	0.34 ²	0.15 ²	0.04 ²	-	-	-	-	-
RP 250 E	-50 ... 200	0.05	Hybrid	2.5	-	-	1.50 ³	1.44 ³	1.20 ³	0.84 ³	0.54 ²	0.29 ²	0.11 ²	0.02 ¹	-	-	-	-
RP 250 EC	-50 ... 200	0.05	Hybrid	2.5	-	-	1.50 ³	1.44 ³	1.20 ³	0.84 ³	0.54 ²	0.29 ²	0.11 ²	0.02 ¹	-	-	-	-
RP 290 E	-90 ... 200	0.05	Hybrid	2.5	-	-	0.80 ³	0.77 ³	0.74 ³	0.72 ³	0.70 ²	0.68 ²	0.64 ²	0.56 ²	0.39 ²	0.21 ²	0.09 ²	0.01 ¹
RP 290 EC	-90 ... 200	0.05	Hybrid	2.5	-	-	0.80 ³	0.77 ³	0.74 ³	0.72 ³	0.70 ²	0.68 ²	0.64 ²	0.56 ²	0.39 ²	0.21 ²	0.09 ²	0.01 ¹

LAUDA Integral T / Page 20

IN 130 T	-32 ... 120	0.05	Air	2.7	-	1.40	1.40	1.35	1.20	0.80	0.40	0.10	-	-	-	-	-	-
IN 230 T	-32 ... 120	0.05	Air	2.7	-	2.20	2.20	1.90	1.50	1.00	0.60	0.15	-	-	-	-	-	-
IN 230 TW	-32 ... 120	0.05	Water	2.7	-	2.30	2.30	2.30	1.90	1.30	0.75	0.35	-	-	-	-	-	-
IN 530 T	-32 ... 120	0.05	Air	8.0	-	5.00	5.00	4.50	3.80	2.60	1.50	0.60	-	-	-	-	-	-
IN 530 TW	-32 ... 120	0.05	Water	8.0	-	6.00	6.00	5.50	4.50	3.00	1.60	0.70	-	-	-	-	-	-
IN 1030 T	-32 ... 150	0.10	Air	8.0	-	11.00	11.00	9.50	7.10	4.90	3.00	1.60	-	-	-	-	-	-
IN 1330 TW	-32 ... 150	0.10	Water	16.0	-	13.00	13.00	10.00	7.60	5.40	3.40	1.70	-	-	-	-	-	-
IN 1830 TW	-32 ... 150	0.10	Water	16.0	-	19.00	19.00	15.00	11.50	7.50	5.00	2.70	-	-	-	-	-	-

Pump pressure max. bar	Pump flow max. pressure L/min	Pump connection thread	Bath volume min. L	Bath volume max. L	Dimensions (W x D x H) mm	Protection Rating	Noise level dB (A)	Weight kg	Loading max. kW	Power supply V; Hz	Part Number	Device type
0.8	2.6	Quick C. ¼"	0.26	0.28	175×301×266	IP 21	57	7	0.2	100-240 V; 50/60 Hz	L000027	L 100
0.8	2.6	Quick C. ¼"	0.30	0.32	261×368×312	IP 21	57	12	0.4	100-240 V; 50/60 Hz	L000580	L 250
0.68	22	M16×1	2.4	4.4	250×365×425	IP 21	47	17	2.7	200-230 V; 50/60 Hz	L000019	P 2 E
0.68	22	M16×1	2.4	4.4	250×365×425	IP 21	47	17	2.7	200-230 V; 50/60 Hz	L000020	P 2 EC
0.68	22	M16×1	2.4	4.4	300×430×675	IP 21	54	42	3.7	230 V; 50 Hz	L000021	RP 240 E
0.68	22	M16×1	2.4	4.4	300×430×675	IP 21	54	42	3.7	230 V; 50 Hz	L000023	RP 240 EC
0.68	22	M16×1	2.4	4.4	300×430×675	IP 21	54	39	3.7	230 V; 50 Hz	L000022	RP 245 E
0.68	22	M16×1	2.4	4.4	300×430×675	IP 21	54	43	3.7	230 V; 50 Hz	L000024	RP 245 EC
0.68	22	M16×1	2.4	4.4	300×430×675	IP 21	57	47	3.7	230 V; 50 Hz	L002494	RP 250 E
0.68	22	M16×1	2.4	4.4	300×430×675	IP 21	57	48	3.7	230 V; 50 Hz	L002495	RP 250 EC
0.68	22	M16×1	2.4	4.4	390×600×685	IP 21	56	77	3.7	230 V; 50 Hz	L002502	RP 290 E
0.68	22	M16×1	2.4	4.4	390×600×685	IP 21	56	79	3.7	230 V; 50 Hz	L002503	RP 290 EC
3.5	40	G ¾	3.6	8.7	430×550×760	IP 21	61	79	3.7	230 V; 50 Hz	L002663**	IN 130 T
3.5	40	G ¾	3.6	8.7	430×550×760	IP 21	63	84	3.7	230 V; 50 Hz	L002664**	IN 230 T
3.5	40	G ¾	3.6	8.7	430×550×760	IP 21	60	85	3.7	230 V; 50 Hz	L002665**	IN 230 TW
3.5	40	G ¾	7.2	20.5	560×550×1,325	IP 21	66	149	11.0	400 V; 3/PE; 50 Hz & 460 V; 3/PE; 60 Hz	L002666**	IN 530 T
3.5	40	G ¾	7.2	20.5	560×550×1,325	IP 21	62	150	11.0	400 V; 3/PE; 50 Hz & 460 V; 3/PE; 60 Hz	L002667**	IN 530 TW
5.5	60	M38×1.5	9.7	25.5	760×650×1,605	IP 21	70	223	11.0	400 V; 3/PE; 50 Hz & 460 V; 3/PE; 60 Hz	L002668**	IN 1030 T
5.5	60	M38×1.5	9.7	25.5	760×650×1,605	IP 21	62	225	18.0	400 V; 3/PE; 50 Hz & 460 V; 3/PE; 60 Hz	L002669**	IN 1330 TW
5.5	60	M38×1.5	9.7	25.5	760×650×1,605	IP 21	67	244	18.0	400 V; 3/PE; 50 Hz & 460 V; 3/PE; 60 Hz	L002670**	IN 1830 TW

** Utilises traditional refrigerants (HFCs) in accordance with European legislation to control F-gases (EU) 573/2024. Detailed information can be found on the respective product detail page of the part number at www.lauda.de

LAUDA Circulation and process thermostats

Technical data according to DIN 12876 standard

Device type	Working temperature range °C	Temperature stability ±K	Cooling of the refrigerating machine	Heater power max. kW	Cooling output kW													
					200 °C	100 °C	20 °C	10 °C	0 °C	-10 °C	-20 °C	-30 °C	-40 °C	-50 °C	-60 °C	-70 °C	-80 °C	-90 °C
LAUDA Integral XT / Page 22																		
IN 150 XT	-45 ... 220	0.05	Air	3.5	1.50 ³	1.50 ³	1.50 ³	1.50 ³	1.30 ³	1.00 ³	0.70 ²	0.30 ²	0.06 ²	-	-	-	-	-
IN 250 XTW	-45 ... 220	0.05	Water	3.5	2.20 ³	2.20 ³	2.10 ³	2.00 ³	1.80 ³	1.40 ³	1.00 ²	0.55 ²	0.20 ²	-	-	-	-	-
IN 550 XT	-50 ... 220	0.05	Air	8.0	5.00 ³	5.00 ³	5.00 ³	4.80 ³	4.60 ³	3.30 ³	2.30 ²	1.20 ²	0.50 ²	0.10 ¹	-	-	-	-
IN 550 XTW	-50 ... 220	0.05	Water	8.0	5.80 ³	5.80 ³	5.80 ³	5.80 ³	5.40 ³	4.00 ³	2.60 ²	1.45 ²	0.55 ²	0.12 ¹	-	-	-	-
IN 750 XT	-45 ... 220	0.05	Air	8.0	7.00 ³	7.00 ³	7.00 ³	7.00 ³	5.40 ³	3.60 ³	2.60 ²	1.60 ²	0.80 ²	-	-	-	-	-
IN 950 XTW	-50 ... 220	0.05	Water	8.0	9.50 ³	9.50 ³	9.50 ³	8.50 ³	6.20 ³	4.30 ³	3.00 ²	1.70 ²	0.90 ²	0.35 ¹	-	-	-	-
IN 1850 XTW	-50 ... 220	0.05	Water	16.0	20.00 ³	20.00 ³	20.00 ³	15.00 ³	11.50 ³	8.50 ³	6.10 ²	3.60 ²	1.90 ²	1.10 ¹	-	-	-	-
IN 2560 XTW	-60 ... 220	0.10	Water	24.0	25.00 ³	25.00 ³	25.00 ³	24.50 ³	22.50 ³	22.00 ³	18.50 ²	12.50 ²	8.70 ²	5.00 ¹	3.00 ²	-	-	-
IN 280 XT	-80 ... 220	0.05	Air	4.0	1.60 ³	1.60 ³	1.60 ³	1.55 ³	1.50 ³	1.50 ³	1.70 ²	1.70 ²	1.65 ²	1.40 ²	0.85 ²	0.35 ²	0.15 ²	-
IN 280 XTW	-80 ... 220	0.05	Water	4.0	1.70 ³	1.70 ³	1.70 ³	1.65 ³	1.60 ³	1.60 ³	1.80 ²	1.80 ²	1.80 ²	1.50 ²	0.90 ²	0.45 ²	0.18 ²	-
IN 590 XTW	-90 ... 220	0.05	Water	8.0	4.50 ³	4.50 ³	4.50 ³	4.45 ³	4.40 ³	4.40 ³	4.60 ²	4.60 ²	4.50 ²	4.20 ²	2.70 ²	1.40 ²	0.60 ²	0.20 ¹
IN 1590 XTW	-90 ... 220	0.05	Water	12.0	18.50 ³	18.50 ³	18.50 ³	15.00 ³	11.50 ³	8.70 ³	8.50 ²	8.50 ²	7.50 ²	6.00 ²	4.00 ²	2.20 ²	0.90 ²	0.35 ¹
LAUDA Integral XT with natural refrigerant / Page 22																		
IN 550 XT	-50 ... 220	0.05	Air	8.0	5.00 ³	5.00 ³	5.00 ³	4.80 ³	4.60 ³	3.30 ³	2.40 ²	1.50 ²	0.70 ²	0.30 ¹	-	-	-	-
IN 550 XTW	-50 ... 220	0.05	Water	8.0	5.80 ³	5.80 ³	5.80 ³	5.80 ³	5.40 ³	4.00 ³	2.80 ²	1.70 ²	0.75 ²	0.35 ¹	-	-	-	-
IN 750 XT	-50 ... 220	0.05	Air	8.0	7.00 ³	7.00 ³	7.00 ³	6.30 ³	4.80 ³	3.60 ³	2.60 ²	1.70 ²	0.85 ²	0.40 ¹	-	-	-	-
IN 950 XTW	-50 ... 220	0.05	Water	8.0	9.00 ³	9.00 ³	9.00 ³	7.80 ³	5.80 ³	4.20 ³	3.00 ²	1.90 ²	0.95 ²	0.50 ¹	-	-	-	-
IN 1850 XTW	-50 ... 220	0.05	Water	16.0	20.00 ³	20.00 ³	20.00 ³	17.80 ³	13.20 ³	9.40 ³	6.80 ²	4.20 ²	2.20 ²	1.35 ¹	-	-	-	-
LAUDA Integral XT with CO₂ refrigerant / Page 22																		
IN 2040 XTW	-45 ... 200	0.05	Water	16.0	20.80 ³	20.80 ³	20.80 ³	20.50 ³	17.80 ³	14.00 ³	10.50 ²	6.60 ²	3.50 ²	-	-	-	-	-
IN 3540 XTW	-45 ... 200	0.10	Water	24.0	35.00 ³	35.00 ³	35.00 ³	31.50 ³	28.50 ³	22.50 ³	18.50 ²	12.50 ²	7.00 ²	-	-	-	-	-

* Cooling water supply must be provided for operation

¹Pump output step 2 ²Pump output step 4 ³Pump output step 8

Pump pressure max. bar	Pump flow max. pressure L/min	Pump connection thread	Bath volume min. L	Bath volume max. L	Dimensions (W x D x H) mm	Protection Rating	Noise level dB (A)	Weight kg	Loading max. kW	Power supply V; Hz	Part Number	Device type
3.1	65	M30×1.5	2.5	8.7	430×550×760	IP 21	60	106	3.7	230 V; 50 Hz	L002673**	IN 150 XT
3.1	65	M30×1.5	2.5	8.7	430×550×760	IP 21	57	106	3.7	230 V; 50 Hz	L002674**	IN 250 XTW
3.1	65	M30×1.5	4.8	17.2	560×550×1,325	IP 21	66	177	10.5	400 V; 3/PE; 50 Hz & 460 V; 3/PE; 60 Hz	L002675**	IN 550 XT
3.1	65	M30×1.5	4.8	17.2	560×550×1,325	IP 21	66	177	10.5	400 V; 3/PE; 50 Hz & 460 V; 3/PE; 60 Hz	L002676**	IN 550 XTW
3.1	65	M30×1.5	4.8	17.2	560×550×1,325	IP 21	68	176	11.0	400 V; 3/PE; 50 Hz & 460 V; 3/PE; 60 Hz	L002677**	IN 750 XT
3.1	65	M30×1.5	4.8	17.2	560×550×1,325	IP 21	69	176	11.0	400 V; 3/PE; 50 Hz & 460 V; 3/PE; 60 Hz	L002678**	IN 950 XTW
6.0	120	M38×1.5	8.0	28.6	760×650×1,605	IP 21	62	288	18.0	400 V; 3/PE; 50 Hz & 460 V; 3/PE; 60 Hz	L002680**	IN 1850 XTW
6.0	100	M38×1.5	12.6	34.4	1,100×895×1,865	IP 21	74	613	37.0	400 V; 3/PE; 50 Hz & 460 V; 3/PE; 60 Hz	L002681**	IN 2560 XTW
3.1	65	M30×1.5	4.8	17.2	560×550×1,325	IP 21	63	198	9.0	400 V; 3/PE; 50 Hz & 460 V; 3/PE; 60 Hz	L002684**	IN 280 XT
3.1	65	M30×1.5	4.8	17.2	560×550×1,325	IP 21	62	195	9.0	400 V; 3/PE; 50 Hz & 460 V; 3/PE; 60 Hz	L002685**	IN 280 XTW
3.1	65	M30×1.5	8.0	28.6	760×650×1,605	IP 21	64	279	11.0	400 V; 3/PE; 50 Hz & 460 V; 3/PE; 60 Hz	L002687**	IN 590 XTW
3.1	65	M38×1.5	10.0	30.6	760×650×1,605	IP 21	65	356	19.0	400 V; 3/PE; 50 Hz & 460 V; 3/PE; 60 Hz	L002689**	IN 1590 XTW
3.1	65	M30×1.5	4.8	17.2	560×550×1,325	IP 21	65	176	10.5	400 V; 3/PE; 50 Hz	L004069	IN 550 XT
3.1	65	M30×1.5	4.8	17.2	560×550×1,325	IP 21	60	181	10.5	400 V; 3/PE; 50 Hz	L004070	IN 550 XTW
3.1	65	M30×1.5	4.8	17.2	560×550×1,325	IP 21	65	176	11.0	400 V; 3/PE; 50 Hz	L004063	IN 750 XT
3.1	65	M30×1.5	4.8	17.2	560×550×1,325	IP 21	60	181	11.0	400 V; 3/PE; 50 Hz	L003681	IN 950 XTW
6.0	120	M30×1.5	8.0	28.6	760×650×1,605	IP 21	60	310	18.0	400 V; 3/PE; 50 Hz & 460 V; 3/PE; 60 Hz	L004064	IN 1850 XTW
6.0	120	M38×1.5	10.5	30.0	760×650×1,605	IP 21	61	454	18.0	400 V; 3/PE; 50 Hz & 460 V; 3/PE; 60 Hz	L004065	IN 2040 XTW
6.0	100	M38×1.5	15.6	37.4	1,100×895×1,865	IP 21	75	600	-	400 V; 3/PE; 50 Hz & 460 V; 3/PE; 60 Hz	L004071	IN 3540 XTW

** Utilises traditional refrigerants (HFCs) in accordance with European legislation to control F-gases (EU) 573/2024. Detailed information can be found on the respective product detail page of the part number at www.lauda.de

LAUDA Circulation and process thermostats

Technical data according to DIN 12876 standard

Device type	Working temperature range °C	Temperature stability ±K	Cooling of the refrigerating machine	Heater power max. kW	Cooling output kW													
					200 °C	100 °C	20 °C	10 °C	0 °C	-10 °C	-20 °C	-30 °C	-40 °C	-50 °C	-60 °C	-70 °C	-80 °C	-90 °C

LAUDA Integral XT High-temperature thermostats / Page 22

IN 4 XTW*	25 ... 320	0.10	Water	3.5	17.00 ³	10.00 ²	-	-	-	-	-	-	-	-	-	-	-	-
IN 8 XTW*	25 ... 320	0.10	Water	8.0	17.00 ³	10.00 ²	-	-	-	-	-	-	-	-	-	-	-	-

LAUDA Integral P / Page 24

IN 2050 PW	-40 ... 140	0.05	Water	16.0	-	20.00 ³	20.00 ³	15.00 ³	10.80 ³	7.80 ³	4.80 ²	3.00 ²	1.60 ²	-	-	-	-	-
IN 2560 PW	-40 ... 140	0.10	Water	24.0	-	25.00 ³	25.00 ³	25.00 ³	24.50 ³	24.00 ³	17.70 ³	11.00 ³	7.50 ³	-	-	-	-	-

LAUDA Integral P with CO₂ refrigerant / Page 24

IN 2040 PW	-40 ... 140	0.05	Water	16.0	-	20.80 ³	20.80 ³	20.00 ³	17.00 ³	13.00 ³	9.20 ²	5.30 ²	3.00 ²	-	-	-	-	-
IN 3540 PW	-40 ... 140	0.10	Water	24.0	-	35.00 ³	35.00 ³	34.00 ³	33.00 ³	26.00 ³	18.50 ²	9.00 ²	5.40 ²	-	-	-	-	-

LAUDA Variocool with natural refrigerant / Page 28

VC 1200	-25 ... 80	0.05	Air	2.3	-	-	1.30	1.20	1.05	0.80	0.50	-	-	-	-	-	-	-
VC 1200	-25 ... 80	0.05	Air	2.6	-	-	1.22	1.12	0.97	0.72	0.42	-	-	-	-	-	-	-
VC 1200 W	-25 ... 80	0.05	Water	2.3	-	-	1.40	1.30	1.10	0.85	0.53	-	-	-	-	-	-	-
VC 1200 W	-25 ... 80	0.05	Water	2.6	-	-	1.32	1.22	1.02	0.77	0.45	-	-	-	-	-	-	-
VC 2000	-25 ... 80	0.05	Air	2.3	-	-	2.00	1.60	1.25	0.90	0.57	-	-	-	-	-	-	-
VC 2000	-25 ... 80	0.05	Air	2.6	-	-	1.92	1.52	1.17	0.82	0.49	-	-	-	-	-	-	-
VC 2000 W	-25 ... 80	0.05	Water	2.3	-	-	2.10	1.85	1.30	0.95	0.62	-	-	-	-	-	-	-
VC 2000 W	-25 ... 80	0.05	Water	2.6	-	-	2.02	1.77	1.22	0.87	0.54	-	-	-	-	-	-	-

* Cooling water supply must be provided for operation

¹Pump output step 2 ²Pump output step 4 ³Pump output step 8

Pump pressure max. bar	Pump flow max. pressure L/min	Pump connection thread	Bath volume min. L	Bath volume max. L	Dimensions (W x D x H) mm	Protection Rating	Noise level dB (A)	Weight kg	Loading max. kW	Power supply V; Hz	Part Number	Device type
3.1	60	M30×1.5	3.3	9.5	430×550×760	IP 21	52	52	3.7	230 V; 50 Hz	L002682	IN 4 XTW
3.1	60	M30×1.5	3.6	9.8	430×550×760	IP 21	52	86	9.0	400 V; 3/PE; 50 Hz & 460 V; 3/PE; 60 Hz	L002683	IN 8 XTW
6.0	120	M38×1.5	11.1	36.3	1,100×895×1,865	IP 21	58	382	18.0	400 V; 3/PE; 50 Hz & 460 V; 3/PE; 60 Hz	L003214**	IN 2050 PW
6.0	100	M38×1.5	12.1	48.1	1,100×895×1,865	IP 21	74	625	37.0	400 V; 3/PE; 50 Hz & 460 V; 3/PE; 60 Hz	L003308**	IN 2560 PW
6.0	120	M38×1.5	11.5	41.0	1,100×895×1,865	IP 21	61	508	18.0	400 V; 3/PE; 50 Hz & 460 V; 3/PE; 60 Hz	L004350	IN 2040 PW
6.0	100	M38×1.5	15.6	37.4	1,100×895×1,865	IP 21	75	612	-	400 V; 3/PE; 50 Hz & 460 V; 3/PE; 60 Hz	L004351	IN 3540 PW
0.9	28	G ¾	8.0	15	450×550×650	IP 32	51	51	2.7	230 V; 50 Hz	L004353	VC 1200
3.2	37	G ¾	8.0	15	450×550×790	IP 32	51	58	3.1	230 V; 50 Hz	L004354	VC 1200
0.9	28	G ¾	8.0	15	450×550×650	IP 32	50	50	2.7	230 V; 50 Hz	L004356	VC 1200 W
3.2	37	G ¾	8.0	15	450×550×790	IP 32	50	57	3.0	230 V; 50 Hz	L004357	VC 1200 W
0.9	28	G ¾	8.0	15	450×550×650	IP 32	52	51	2.8	230 V; 50 Hz	L004072	VC 2000
3.2	37	G ¾	8.0	15	450×550×790	IP 32	52	58	3.1	230 V; 50 Hz	L004073	VC 2000
0.9	28	G ¾	8.0	15	450×550×650	IP 32	50	50	2.7	230 V; 50 Hz	L004074	VC 2000 W
3.2	37	G ¾	8.0	15	450×550×790	IP 32	50	57	3.1	230 V; 50 Hz	L004075	VC 2000 W

** Utilises traditional refrigerants (HFCs) in accordance with European legislation to control F-gases (EU) 573/2024. Detailed information can be found on the respective product detail page of the part number at www.lauda.de

LAUDA Circulation and process thermostats

Technical data according to DIN 12876 standard

Device type	Working temperature range °C	Temperature stability ±K	Cooling of the refrigerating machine	Heater power max. kW	Cooling output kW													
					200 °C	100 °C	20 °C	10 °C	0 °C	-10 °C	-20 °C	-30 °C	-40 °C	-50 °C	-60 °C	-70 °C	-80 °C	-90 °C

LAUDA Variocool / Page 28

VC 3000	-20 ... 80	0.05	Air	1.5	-	-	3.00	2.40	1.68	0.95	0.45	-	-	-	-	-	-
VC 3000	-20 ... 80	0.05	Air	1.5	-	-	2.80	2.20	1.48	0.75	0.25	-	-	-	-	-	-
VC 3000 W	-20 ... 80	0.05	Water	1.5	-	-	3.00	2.40	1.68	0.95	0.45	-	-	-	-	-	-
VC 3000 W	-20 ... 80	0.05	Water	1.5	-	-	2.80	2.20	1.48	0.75	0.25	-	-	-	-	-	-
VC 5000	-20 ... 80	0.05	Air	4.5	-	-	5.00	3.90	2.75	1.70	0.90	-	-	-	-	-	-
VC 5000	-20 ... 80	0.05	Air	4.5	-	-	4.65	3.55	2.40	1.35	0.55	-	-	-	-	-	-
VC 5000 W	-20 ... 80	0.05	Water	4.5	-	-	5.00	3.90	2.75	1.70	0.90	-	-	-	-	-	-
VC 5000 W	-20 ... 80	0.05	Water	4.5	-	-	4.65	3.55	2.40	1.35	0.55	-	-	-	-	-	-
VC 7000	-25 ... 80	0.10	Air	4.5	-	-	7.00	5.30	3.70	2.40	1.30	-	-	-	-	-	-
VC 7000	-25 ... 80	0.10	Air	4.5	-	-	6.65	4.95	3.35	2.05	0.95	-	-	-	-	-	-
VC 7000 W	-25 ... 80	0.10	Water	4.5	-	-	7.00	5.30	3.70	2.40	1.30	-	-	-	-	-	-
VC 7000 W	-25 ... 80	0.10	Water	4.5	-	-	6.65	4.95	3.35	2.05	0.95	-	-	-	-	-	-
VC 10000	-25 ... 80	0.10	Air	7.5	-	-	10.00	7.60	5.30	3.50	2.00	-	-	-	-	-	-
VC 10000	-25 ... 80	0.10	Air	7.5	-	-	9.65	7.25	4.95	3.15	1.65	-	-	-	-	-	-
VC 10000 W	-25 ... 80	0.10	Water	7.5	-	-	10.00	7.60	5.30	3.50	2.00	-	-	-	-	-	-
VC 10000 W	-25 ... 80	0.10	Water	7.5	-	-	9.65	7.25	4.95	3.15	1.65	-	-	-	-	-	-

LAUDA Ultratemp / Page 30

UT 2505 W	-5 ... 60	0.50	Water	35.0	-	-	25.80	19.10	13.80	-	-	-	-	-	-	-	-
UT 3505 W	-5 ... 60	0.50	Water	35.0	-	-	35.30	26.20	18.70	-	-	-	-	-	-	-	-
UT 5005 W	-5 ... 60	0.50	Water	50.0	-	-	46.70	34.30	24.40	-	-	-	-	-	-	-	-

LAUDA Semistat / Page 32

S 1200	-20 ... 90	0.10	Water	3.0	-	-	1.20	0.90	0.60	0.35	0.08	-	-	-	-	-	-
S 2400	-20 ... 90	0.10	Water	6.0	-	-	2.45	1.93	1.40	0.88	0.35	-	-	-	-	-	-
S 4400	-20 ... 90	0.10	Water	12.0	-	-	4.40	3.50	2.60	1.65	0.70	-	-	-	-	-	-

Pump pressure max. bar	Pump flow max. pressure L/min	Pump connection thread	Bath volume min. L	Bath volume max. L	Dimensions (W x D x H) mm	Protection Rating	Noise level dB (A)	Weight kg	Loading max. kW	Power supply V; Hz	Part Number	Device type
3.2	37	G ¾	20	33	550×650×970	IP 32	57	89	2.6	230 V; 50 Hz	L000715*	VC 3000
4.8	37	G ¾	20	33	550×650×970	IP 32	61	89	2.6	230 V; 50 Hz	L000929*	VC 3000
3.2	37	G ¾	20	33	550×650×970	IP 32	55	88	2.6	230 V; 50 Hz	L000735*	VC 3000 W
4.8	37	G ¾	20	33	550×650×970	IP 32	59	88	2.6	230 V; 50 Hz	L000962*	VC 3000 W
3.2	37	G ¾	20	33	550×650×970	IP 32	65	97	7.8	400 V; 3/N/PE; 50 Hz	L000728*	VC 5000
5.0	60	G ¾	20	33	550×650×970	IP 32	69	97	7.8	400 V; 3/N/PE; 50 Hz	L000949*	VC 5000
3.2	37	G ¾	20	33	550×650×970	IP 32	64	97	7.8	400 V; 3/N/PE; 50 Hz	L000746*	VC 5000 W
5.0	60	G ¾	20	33	550×650×970	IP 32	68	97	7.8	400 V; 3/N/PE; 50 Hz	L001995*	VC 5000 W
3.2	37	G 1¼	48	64	650×670×1,250	IP 32	66	124	8.8	400 V; 3/N/PE; 50 Hz	L000729*	VC 7000
5.0	60	G 1¼	48	64	650×670×1,250	IP 32	69	124	8.8	400 V; 3/N/PE; 50 Hz	L000951*	VC 7000
3.2	37	G 1¼	48	64	650×670×1,250	IP 32	60	122	8.8	400 V; 3/N/PE; 50 Hz	L000747*	VC 7000 W
5.0	60	G 1¼	48	64	650×670×1,250	IP 32	64	133	8.8	400 V; 3/N/PE; 50 Hz	L000983*	VC 7000 W
3.2	37	G 1¼	48	64	650×670×1,250	IP 32	67	137	11.1	400 V; 3/N/PE; 50 Hz	L000730*	VC 10000
5.0	60	G 1¼	48	64	650×670×1,250	IP 32	70	137	11.1	400 V; 3/N/PE; 50 Hz	L000953*	VC 10000
3.2	37	G 1¼	48	64	650×670×1,250	IP 32	61	131	11.1	400 V; 3/N/PE; 50 Hz	L000748*	VC 10000 W
5.0	60	G 1¼	48	64	650×670×1,250	IP 32	65	131	11.1	400 V; 3/N/PE; 50 Hz	L000985*	VC 10000 W
3.2	250	Rp 1½	-	100.0	1,138×1,486×1,792	IP 54	47**	520	40.7***	400 V; 3/PE; 50 Hz	L004022*	UT 2505 W
3.2	250	Rp 1½	-	100.0	1,138×1,486×1,792	IP 54	49**	585	42.1***	400 V; 3/PE; 50 Hz	L004024*	UT 3505 W
4.8	250	Rp 1½	-	100.0	1,138×1,728×1,722	IP 54	50**	700	59.6***	400 V; 3/PE; 50 Hz	L004026*	UT 5005 W
2.8	22	½"	1.00	1.30	116×232×470	-	-	15	-	Connection to PSC	L003276	S 1200
2.8	22	½"	1.25	1.60	116×300×560	-	-	27	-	Connection to PSC	L003277	S 2400
2.8	27	½"	2.50	2.80	194×300×560	-	-	38	-	Connection to PSC	L003278	S 4400

* Utilises traditional refrigerants (HFCs) in accordance with European legislation to control F-gases (EU) 573/2024.

Detailed information can be found on the respective product detail page of the part number at www.lauda.de

** at a distance of 5 m under free-field conditions

*** at 20 °C cooling water temperature, 20 °C outflow temperature and maximum heating output

LAUDA Circulation and process thermostats

Power supply variants

Device type	Power supply V; Hz	Heater power max. kW	Pump pressure max. 60 Hz bar	Pump flow max. pressure 60 Hz L/min	Loading max. kW	Plug code*	Part Number	Device type	Power supply V; Hz	Heater power max. kW	Pump pressure max. 60 Hz bar	Pump flow max. pressure 60 Hz L/min	Loading max. kW	Plug code*	Part Number
LAUDA PRO / Page 18															
P 2 E	100-120 V; 50/60 Hz	1.8	0.68	22	1.9	4	L000549	RP 245 EC	100 V; 50/60 Hz	1.3	0.68	22	1.5	14	L000537
P 2 E	200-230 V; 50/60 Hz	2.5	0.68	22	2.7	3	L000045	RP 245 EC	120 V; 60 Hz	1.8	0.68	22	1.9	4	L000457
P 2 EC	100-120 V; 50/60 Hz	1.8	0.68	22	1.9	4	L000553	RP 245 EC	200 V; 50/60 Hz	1.9	0.68	22	3.2	3	L000497
P 2 EC	200-230 V; 50/60 Hz	2.5	0.68	22	2.7	3	L000049	RP 245 EC	208-220 V; 60 Hz	2.3	0.68	22	3.5	3	L000321
RP 240 E	100 V; 50/60 Hz	1.3	0.68	22	1.5	14	L000532	RP 245 EC	208-220 V; 60 Hz	2.3	0.68	22	3.5	2	L000579
RP 240 E	120 V; 60 Hz	1.8	0.68	22	1.9	4	L000452	RP 250 E	200 V; 50/60 Hz	1.9	0.68	22	3.2	3	L002498
RP 240 E	208-220 V; 60 Hz	2.3	0.68	22	3.5	3	L000312	RP 250 E	208-220 V; 60 Hz	2.3	0.68	22	3.5	3	L002657
RP 240 E	208-220 V; 60 Hz	2.3	0.68	22	3.5	2	L000570	RP 250 E	208-220 V; 60 Hz	2.3	0.68	22	3.5	2	L002500
RP 240 EC	100 V; 50/60 Hz	1.3	0.68	22	1.5	14	L000536	RP 250 EC	200 V; 50/60 Hz	1.9	0.68	22	3.2	3	L002499
RP 240 EC	120 V; 60 Hz	1.8	0.68	22	1.9	4	L000456	RP 250 EC	208-220 V; 60 Hz	2.3	0.68	22	3.5	2	L002501
RP 240 EC	200 V; 50/60 Hz	1.9	0.68	22	3.2	3	L000496	RP 250 EC	208-220 V; 60 Hz	2.3	0.68	22	3.5	3	L002658
RP 240 EC	208-220 V; 60 Hz	2.3	0.68	22	3.5	3	L000320	RP 290 E	200 V; 50/60 Hz	1.9	0.68	22	3.2	3	L002506
RP 245 E	100 V; 50/60 Hz	1.3	0.68	22	1.5	14	L000533	RP 290 E	208-220 V; 60 Hz	2.3	0.68	22	3.5	3	L002659
RP 245 E	120 V; 60 Hz	1.8	0.68	22	1.9	4	L000453	RP 290 E	208-220 V; 60 Hz	2.3	0.68	22	3.5	2	L002508
RP 245 E	200 V; 50/60 Hz	1.9	0.68	22	3.2	3	L000489	RP 290 EC	200 V; 50/60 Hz	1.9	0.68	22	3.2	3	L002507
RP 245 E	208-220 V; 60 Hz	2.3	0.68	22	3.5	2	L000571	RP 290 EC	208-220 V; 60 Hz	2.3	0.68	22	3.5	2	L002509
RP 245 E	208-220 V; 60 Hz	2.3	0.68	22	3.5	3	L000313	RP 290 EC	208-220 V; 60 Hz	2.3	0.68	22	3.5	3	L002660
LAUDA Integral T / Page 20															
IN 130 T	200 V; 50/60 Hz	2.2	4.5	45	3.2	3	L002787	IN 530 T	400 V; 3/PE; 50 Hz & 460 V; 3/PE; 60 Hz	8.0	4.6	65	11.0	34	L002883
IN 130 T	208-220 V; 60 Hz	2.7	4.5	45	3.5	3	L002788	IN 530 TW	400 V; 3/PE; 50 Hz & 460 V; 3/PE; 60 Hz	8.0	4.6	65	11.0	34	L002884
IN 130 T	208-220 V; 60 Hz	2.7	4.5	45	3.5	2	L003301	IN 1030 T	400 V; 3/PE; 50 Hz & 460 V; 3/PE; 60 Hz	8.0	7	70	11.0	34	L002885
IN 230 T	200 V; 50/60 Hz	2.2	4.5	45	3.2	3	L002789	IN 1330 TW	400 V; 3/PE; 50 Hz & 460 V; 3/PE; 60 Hz	16.0	7	70	18.0	33	L002886
IN 230 T	208-220 V; 60 Hz	2.7	4.5	45	3.5	2	L003302	IN 1830 TW	400 V; 3/PE; 50 Hz & 460 V; 3/PE; 60 Hz	16.0	7	70	18.0	33	L003274
IN 230 T	208-220 V; 60 Hz	2.7	4.5	45	3.5	3	L002791								
IN 230 TW	200 V; 50/60 Hz	2.2	4.5	45	3.2	3	L002790								
IN 230 TW	208-220 V; 60 Hz	2.7	4.5	45	3.5	2	L003303								
IN 230 TW	208-220 V; 60 Hz	2.7	4.5	45	3.5	3	L002792								

*All data for the plug codes can be found on page 142

**Technical data NRTL according to UL and CSA

Device type	Power supply V; Hz	Heater power max. kW	Pump pressure max. 60 Hz bar	Pump flow max. pressure 60 Hz L/min	Loading max. kW	Plug code*	Part Number	Device type	Power supply V; Hz	Heater power max. kW	Pump pressure max. 60 Hz bar	Pump flow max. pressure 60 Hz L/min	Loading max. kW	Plug code*	Part Number
LAUDA Integral XT / Page 22															
IN 150 XT	200 V; 50/60 Hz	3.0	3.1	65	3.2	3	L002793	IN 750 XT	400 V; 3/PE; 50 Hz & 460 V; 3/PE; 60 Hz	8.0	3.1	65	11.0	34	L002889
IN 150 XT	208-220 V; 60 Hz	3.3	3.1	65	3.5	3	L002794	IN 950 XTW	400 V; 3/PE; 50 Hz & 460 V; 3/PE; 60 Hz	8.0	3.1	65	11.0	34	L002890
IN 150 XT	208-220 V; 60 Hz	3.3	3.1	65	3.5	2	L003304	IN 1850 XTW	400 V; 3/PE; 50 Hz & 460 V; 3/PE; 60 Hz	16.0	6.0	120	18.0	33	L002895
IN 250 XTW	200 V; 50/60 Hz	3.1	3.1	65	3.2	3	L002795	IN 280 XT	400 V; 3/PE; 50 Hz & 460 V; 3/PE; 60 Hz	4.0	3.1	65	9.0	34	L002892
IN 250 XTW	208-220 V; 60 Hz	3.4	3.1	65	3.5	2	L003305	IN 280 XTW	400 V; 3/PE; 50 Hz & 460 V; 3/PE; 60 Hz	4.0	3.1	65	9.0	34	L002893
IN 250 XTW	208-220 V; 60 Hz	3.4	3.1	65	3.5	3	L002796	IN 590 XTW	400 V; 3/PE; 50 Hz & 460 V; 3/PE; 60 Hz	8.0	3.1	65	11.0	34	L002897
IN 550 XT	400 V; 3/PE; 50 Hz & 460 V; 3/PE; 60 Hz	8.0	3.1	65	10.5	34	L002887	IN 1590 XTW	400 V; 3/PE; 50 Hz & 460 V; 3/PE; 60 Hz	12.0	3.1	65	19.0	33	L002898
IN 550 XTW	400 V; 3/PE; 50 Hz & 460 V; 3/PE; 60 Hz	8.0	3.1	65	10.5	34	L002888								
LAUDA Integral XT with CO₂ refrigerant / Page 22															
IN 2040 XTW	400 V; 3/PE; 50 Hz & 460 V; 3/PE; 60 Hz	16.0	6.0	120	18.0	33	L004491								
LAUDA Integral XT High-temperature thermostats / Page 22															
IN 4 XTW	200 V; 50/60 Hz	2.9	3.1	60	3.2	3	L002799	IN 8 XTW	400 V; 3/PE; 50 Hz & 460 V; 3/PE; 60 Hz	8.0	3.1	60	9.0	34	L002891
IN 4 XTW	208-220 V; 60 Hz	3.3	3.1	60	3.5	3	L002800								
LAUDA Integral P / Page 24															
IN 2050 PW	400 V; 3/PE; 50 Hz & 460 V; 3/PE; 60 Hz	16.0	6	120	18.0	33	L003319								
LAUDA Integral P with CO₂ refrigerant / Page 24															
IN 2040 PW	400 V; 3/PE; 50 Hz & 460 V; 3/PE; 60 Hz	16.0	6	120	18.0	33	L004585								

** Technical data NRTL according to UL and CSA

LAUDA Circulation and process thermostats

Power supply variants

Device type	Power supply V; Hz	Heater power max. kW	Pump pressure max. 60 Hz ^{bar}	Pump flow max. pressure 60 Hz L /min	Loading max. kW	Plug code*	Part Number	Device type	Power supply V; Hz	Heater power max. kW	Pump pressure max. 60 Hz ^{bar}	Pump flow max. pressure 60 Hz L /min	Loading max. kW	Plug code*	Part Number
LAUDA Variocool with natural refrigerant / Page 28															
VC 1200	200 V; 50/60 Hz	2.0	3.2	37	2.5	3	L004469	VC 2000	200 V; 50/60 Hz	2.0	3.2	37	2.6	3	L004471
VC 1200	208-220 V; 60 Hz	2.4	3.2	37	2.9	3	L004359	VC 2000	208-220 V; 60 Hz	2.4	3.2	37	2.9	3	L004362
VC 1200 W	200 V; 50/60 Hz	2.0	3.2	37	2.4	3	L004470	VC 2000 W	200 V; 50/60 Hz	2.0	3.2	37	2.5	3	L004472
VC 1200 W	208-220 V; 60 Hz	2.4	3.2	37	2.8	3	L004360	VC 2000 W	208-220 V; 60 Hz	2.4	3.2	37	2.9	3	L004361
LAUDA Variocool / Page 28															
VC 3000	200 V; 50/60 Hz	1.0	3.2	37	2.6	3	L000772	VC 7000	200 V; 3/PE; 50/60 Hz	3.4	3.2	37	5.4	33	L000774
VC 3000	208-220 V; 60 Hz	1.3	3.2	37	2.8	3	L000755	VC 7000	208-220 V; 3/PE; 60 Hz	4.1	3.2	37	5.7	33	L000757
VC 3000	200 V; 50/60 Hz	1.1	4.8	37	2.6	3	L001024	VC 7000	200 V; 3/PE; 50/60 Hz	3.4	4.3	60	5.4	33	L001028
VC 3000	208-220 V; 60 Hz	1.3	4.8	37	2.8	3	L000994	VC 7000	208-220 V; 3/PE; 60 Hz	4.1	5.0	60	5.7	33	L000998
VC 3000 W	200 V; 50/60 Hz	1.0	3.2	37	2.6	3	L000780	VC 7000 W	200 V; 3/PE; 50/60 Hz	3.4	3.2	37	5.4	33	L000782
VC 3000 W	208-220 V; 60 Hz	1.3	3.2	37	2.8	3	L000763	VC 7000 W	208-220 V; 3/PE; 60 Hz	4.1	3.2	37	5.7	33	L000765
VC 3000 W	200 V; 50/60 Hz	1.1	4.8	37	2.6	3	L001039	VC 7000 W	200 V; 3/PE; 50/60 Hz	3.4	4.3	60	5.4	33	L001043
VC 3000 W	208-220 V; 60 Hz	1.3	4.8	37	2.8	3	L001009	VC 7000 W	208-220 V; 3/PE; 60 Hz	4.1	5.0	60	5.7	33	L001013
VC 5000	200 V; 3/PE; 50/60 Hz	3.4	3.2	37	4.3	40	L000773	VC 10000	200 V; 3/PE; 50/60 Hz	5.7	3.2	37	7.6	33	L000775
VC 5000	208-220 V; 3/PE; 60 Hz	4.1	3.2	37	4.5	40	L000756	VC 10000	208-220 V; 3/PE; 60 Hz	6.9	3.2	37	7.7	33	L000758
VC 5000	200 V; 3/PE; 50/60 Hz	3.4	4.3	60	4.3	40	L001026	VC 10000	200 V; 3/PE; 50/60 Hz	5.7	4.3	60	7.6	33	L001030
VC 5000	208-220 V; 3/PE; 60 Hz	4.1	5.0	60	4.5	40	L000996	VC 10000	208-220 V; 3/PE; 60 Hz	6.9	5.0	60	7.7	33	L001000
VC 5000 W	200 V; 3/PE; 50/60 Hz	3.4	3.2	37	4.3	40	L000781	VC 10000 W	200 V; 3/PE; 50/60 Hz	5.7	3.2	37	7.6	33	L000783
VC 5000 W	200 V; 3/PE; 50/60 Hz	3.4	4.3	60	4.3	40	L001041	VC 10000 W	208-220 V; 3/PE; 60 Hz	6.9	3.2	37	7.7	33	L000766
VC 5000 W	208-220 V; 3/PE; 60 Hz	4.1	5.0	60	4.5	40	L001011	VC 10000 W	200 V; 3/PE; 50/60 Hz	5.7	4.3	60	7.6	33	L001045
								VC 10000 W	208-220 V; 3/PE; 60 Hz	6.9	5.0	60	7.7	33	L001015
LAUDA Ultratemp / Page 30															
UT 2505 W	400 V; 3/PE; 50 Hz & 460 V; 3/PE; 60 Hz	35.0	4.6	300	-	1	L004023	UT 5005 W	400 V; 3/PE; 50 Hz & 460 V; 3/PE; 60 Hz	50.0	7.0	300	-	1	L004027
UT 3505 W	400 V; 3/PE; 50 Hz & 460 V; 3/PE; 60 Hz	35.0	4.6	300	-	1	L004025								

*All data for the plug codes can be found on page 142

LAUDA Circulation and process thermostats

More characteristics

LAUDA Integral IN 150 XT, 250 XTW, 280 XT, 280 XTW, 590 XT, 590 XTW, 550 XT, 550 XTW, 750 XT, 950 XTW, 1350 XTW, 1590 XTW / Page 22

PUMP CHARACTERISTICS Heat transfer liquid: Water

Pressure bar

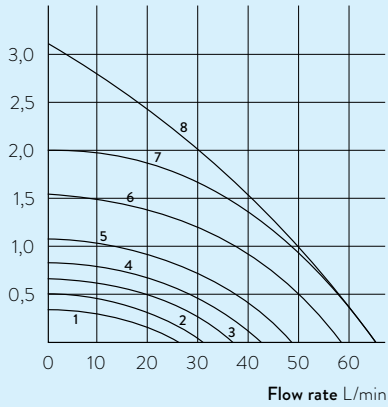

LAUDA Integral IN 4 XTW, IN 8 XTW / Page 22

PUMP CHARACTERISTICS Heat transfer liquid: Water

Pressure bar

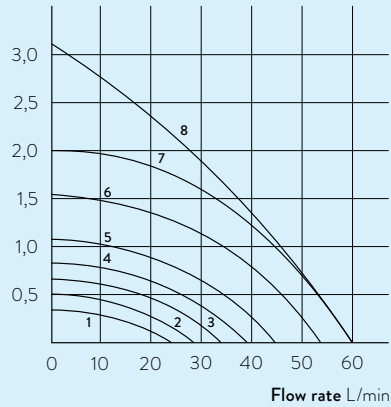

LAUDA Integral IN 1850 XTW, IN 2050 PW, IN 2040 XTW / PW / Page 22, 24

PUMP CHARACTERISTICS Heat transfer liquid: Water

Pressure bar

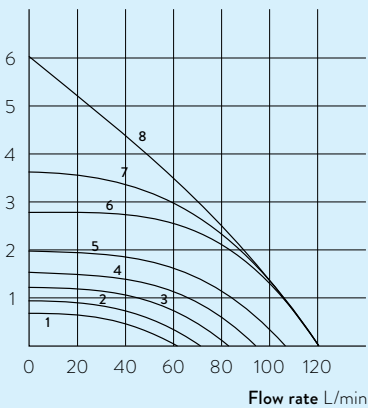

LAUDA Integral IN 2560 XTW / PW, IN 3540 XTW / PW / Page 22, 24

PUMP CHARACTERISTICS Heat transfer liquid: Water

Pressure bar

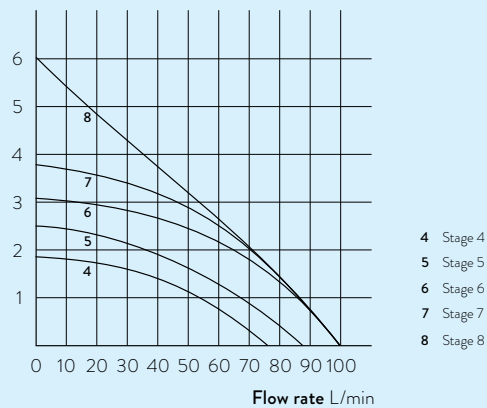

LAUDA Integral IN 130 T, IN 230 T, IN 230 TW, IN 530 T, IN 530 TW / Page 20

PUMP CHARACTERISTICS Heat transfer liquid: Water

Pressure bar

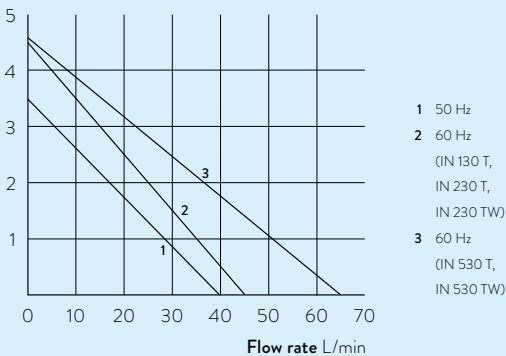

LAUDA Integral IN 1030 T, IN 1330 TW, IN 1830 TW / Page 20

PUMP CHARACTERISTICS Heat transfer liquid: Water

Pressure bar

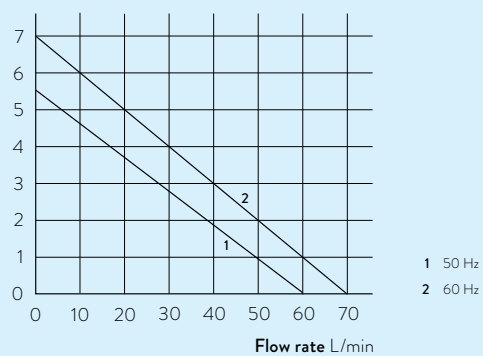

PUMP CHARACTERISTICS 50 Hz Heat transfer liquid: Water

Pressure bar

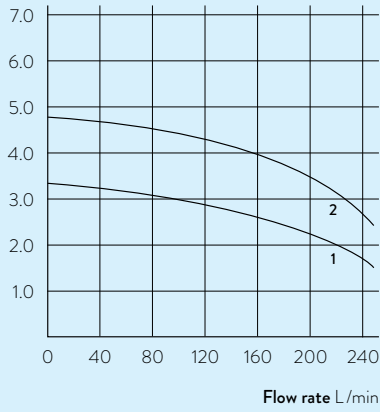

- 2 UT 5005 W
- 1 UT 2505 W, UT 3505 W

PUMP CHARACTERISTICS 60 Hz Heat transfer liquid: Water

Pressure bar

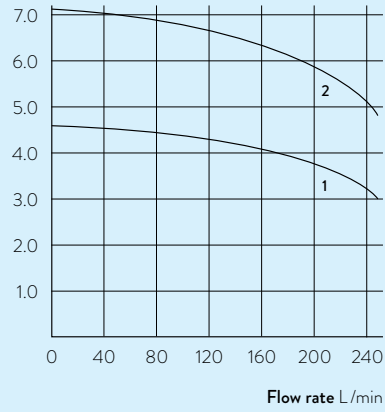

- 2 UT 5005 W
- 1 UT 2505 W, UT 3505 W

PUMP CHARACTERISTIC Heat transfer liquid: Water

Pressure bar

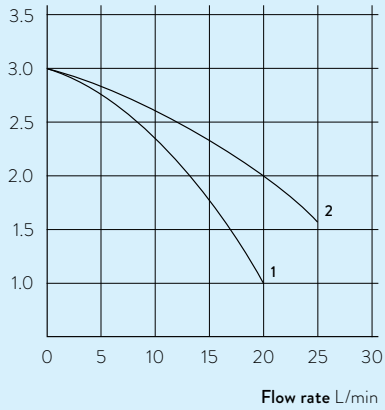

- 2 S 4400
- 1 S 1200, S 2400

The following brand names are registered trademarks
of LAUDA DR. R. WOBSEER GMBH & CO. KG:
LAUDA Microcool®, LAUDA Universa®, LAUDA Variopumpe®,
Kryomat®, Kryopac®, Mobifreeze®, Ultratemp®, Variocool®

LAUDA DR. R. WOBSEER GMBH & CO. KG
Laudaplatz 1 • 97922 Lauda-Königshofen • Germany
www.lauda.de

